



MODEL NO: 81-L Series Butterfly Valve

LUG TYPE, BUTTERFLY VALVE

FLUID APPLICATION: WATER, SEAWATER, AIR, OIL,
POWDER, GAS ETC.

FACE-TO-FACE ACC. TO ISO 5752 SHORT PATTERN ACTUATOR

MOUNTING PAD FLANGE ACC. TO ISO 5211

FLANGE REQUIREMENTS:

ANSI 125/150, BS 10 TABLE E, JIS 2213 10K, DIN PN10/ PN16

RATING:

1-1/2"~ 12" (DN40~DN300): 16 BAR (228PSI)

14"~24" (DN350~DN600): 10 BAR (150PSI)

SIZE RANGE: 1-1/2"-36"

Materials List:

NO.	NAME	MATERIALS	SPECIFICATION		REMARK
			JIS	ASTM	
1	BODY	Cast Iron	FC 20	A126-B	
		DUCTILE IRON	FCD 450	A-536-65-45-12	
		Stainless Steel	SCS13	A351 CF8	
			SCS14	A351 CF8M	
2	DISC	DUCTILE IRON	FCD 45	A-536-65-45-12	Nylon 11 Coating
		STAINLESS STEEL	SCS 13	A351 CF8	
			SCS 14	A351 CF8M	
		ALU-BRONZE	ALBC2	B148-954	
3	STEM	STAINLESS STEEL	SUS 410	A182 F6A	
			SUS 304	A182 F304	
			SUS 316	A182 F316	
4	SEAT	NBR (NITRILE)			-10°C ~ 80°C (14°F ~
		EPDM			-20°C ~ 120°C (-4°F ~
		NEOPRENE (CR)			0°C ~ 80°C (32°F ~
		SILICON			-20°C ~ 180°C (-4°F ~
		HYPALON (CSM)			-20°C ~ 135°C (-4°F ~
		VITON			-18°C ~ 204°C (-4°F ~
5	STOP PIN	STAINLESS STEEL	SUS 316	A182 F316	
6	UPPER BUSH	DELIN			
7	O-RING	NBR (NITRILE)			
8	BACK-UP RING	PLASTIC			
9	BOTTOM BUSH	BRONZE	BC6	ASTM B62	
10	LEVER	DUCTILE IRON	FCD 450	A-536-65-45-12	
11	GEAR BOX	Cast Iron	FC 20	A126-B	

* NBR SEAT APPLICABLE RANGE -10°C ~ 80°C, WHILE

* EPDM SEAT IN -20°C ~ 120°C.

* UPPER BUSHING, MADE BY NON-CORROSSIVE HEAVY DUTY DELIN, STRONGE ENOUGH TO ABSORB THRUST.

* STEM, DESIGNED WITH SQUARE CONNECTION TO DRIVE DISC, ARE RETAINED IN THE BODY AND ANTI-FULL-OUT PROVED BY MEANS OF PATENT "Q" TYPE MECHANISM. WITH THE PATENT MECHANISM THE VALVE CAN BE DISASSEMBLED COMPLETELY BY USE A SIMPLE SCREW DRIVER.

* WARM GEAR, ELECTRIC ACTUATOR, PNEUMATIC ACTUATOR OPERATED BUTTERFLY VALVES ARE AVAILABLE AS REQUESTED.

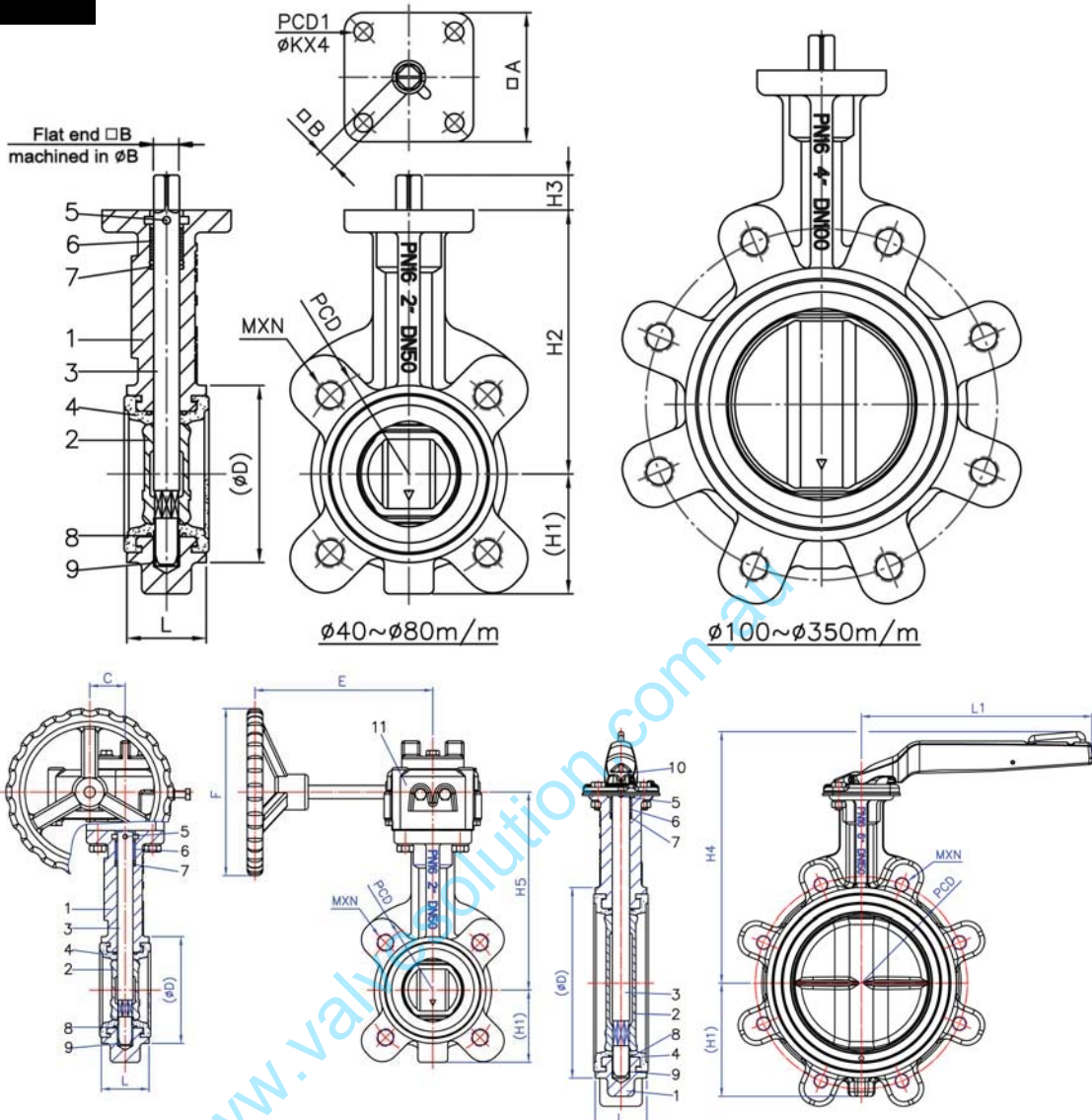

Dimension List:

Size		L	H1	H2	D	H3	□B	§ B	L1	H4	C	E	F	H5	PCD	ISO 5211	Weight Kg
INCH	MM																
1-1/2	40	33	60	120	81	19	11	14	200	181	41	155	150	157	70	F07	2.2
2	50	43	65	143	96	19	11	14	200	204	41	155	150	180	70	F07	3.4
2-1/2	65	46	71	155	110	19	11	14	200	216	41	155	150	192	70	F07	4
3	80	46	77	162	124	19	11	14	200	223	41	155	150	199	70	F07	4.5
4	100	52	107	181	148	19	11	14	200	242	41	155	150	218	70	F07	7.6
5	125	56	122	197	180	19	14	19	250	258	41	155	150	234	70	F07	9.5
6	150	56	140	210	206	19	14	19	250	271	41	155	150	247	70	F07	10.4
8	200	60	165	240	259	24	17	22	355	308	61	195	200	281.5	102	F10	17.5
10	250	68	201	286	320	24	19	25	355	354	61	195	200	327.5	102	F10	26.5
12	300	78	234	309	370	24	22	30	355	377	61	195	200	350.5	102	F10	43.5
14	350	78	301.5	329	412	29	27	35			61	232	310	370	125	F12	58
16	400	102	333.5	361	475	29	32	42			61	232	310	402	125	F12	81
18	450	114	358.5	393	530	38	32	45			81	235	450	445	140	F14	110
20	500	127	392.5	427	585	38	36	50			81	235	450	479	140	F14	155
24	600	154	454.5	492	687	48	46	60			123	307	400	548	165	F16	259

We hereby reserve the rights of any alternative dimension that would help to improve our valve's quality and working efficiency